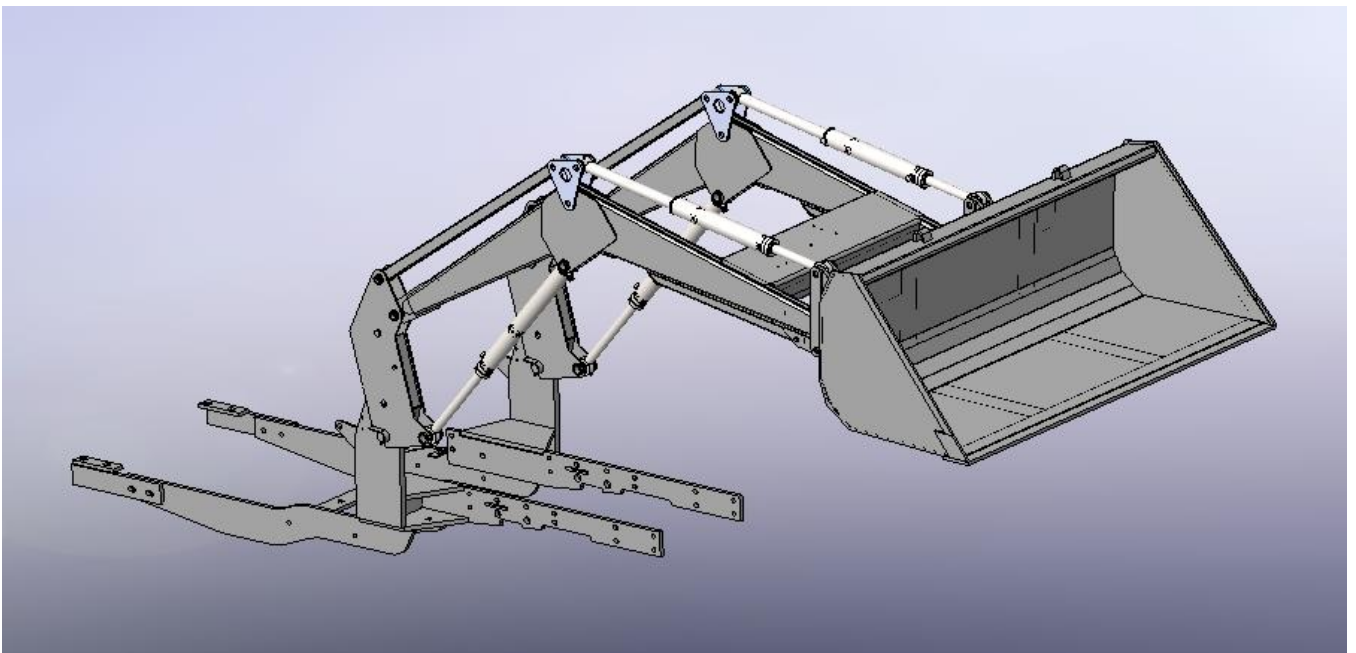




## FRONT LOADER “MTZ”

### Model KR-34



## TECHNICAL SPECIFICATION AND OPERATION MANUAL

Variant B+3F

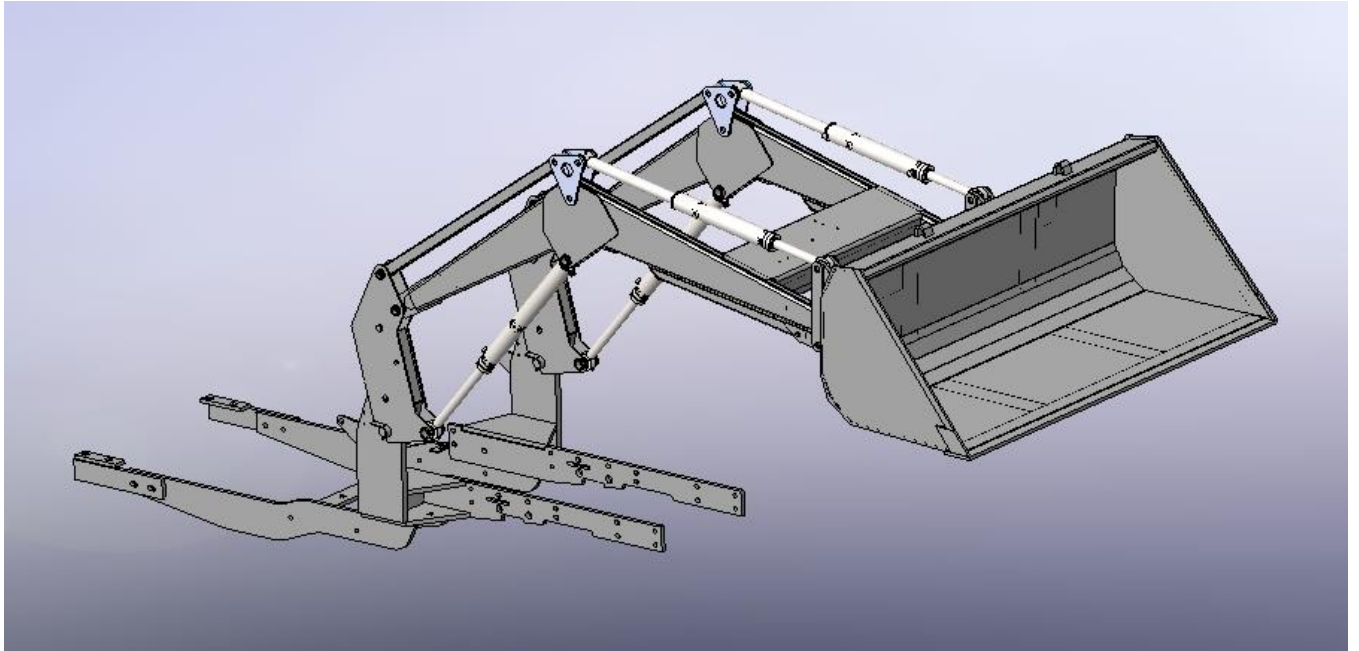
Head Office: 3-1136 Centre St., Ste. 124, Thornhill, Ontario. L4J 3M8 Canada

Warehouse: 2682 Highway 34, Hawkesbury, Ontario. K6A 2R2 Canada

Tel: 1-855-2GO-4MTZ (1-855-246-4689) Fax: 1-647 933-9066 E-mail: [info@mtzequipment.com](mailto:info@mtzequipment.com) Web: [www.mtzequipment.com](http://www.mtzequipment.com)

**Contents:**

	<b>GENERAL CONDITIONS</b>	<b>4</b>
	Warning symbols	4
<b>3</b>	<b>Basic Technical Specification</b>	<b>11</b>
<b>4</b>	<b>Assembly Set</b>	<b>11</b>
<b>6</b>	<b>Control set for additional Distributor by “Joystick”</b>	<b>12</b>
<b>6.1.</b>	<b>Distributor</b>	<b>12</b>
<b>6.2.</b>	<b>Joystick Handle</b>	<b>13</b>
<b>6.3.</b>	<b>3-rd Function Control Set</b>	<b>13</b>
<b>7.</b>	<b>Preparation of MTZ tractor to operations with KR-34 Loader</b>	<b>14</b>
<b>7.1.</b>	<b>Mounting of connecting frame. (Fig.7)</b>	<b>14</b>
<b>7.2.</b>	<b>Connection to the tractor hydraulic system.( Control set “B” )</b>	<b>14</b>
<b>7.2.1.</b>	<b>Alternation ( rearrangement of tractor hydraulic system)</b>	<b>14</b>
<b>7.2.2.</b>	<b>Mounting and connection of the hydraulic distributor</b>	<b>14</b>
<b>8.1</b>	<b>Frontal Loader Operation Control</b>	<b>15</b>
<b>8.2.</b>	<b>Connecting of Front Loader to the tractor</b>	<b>16</b>
<b>8.3.</b>	<b>Disconnecting of Front Loader from the tractor</b>	<b>17</b>
<b>8.4.</b>	<b>Connecting and change of implements</b>	<b>17</b>
<b>8.5.</b>	<b>Connection and change of hydraulically operated implements as units of the “3-rd Function Set”</b>	<b>18</b>
<b>9.</b>	<b>Safety Measures</b>	<b>18</b>
<b>10.</b>	<b>PROHIBITED</b>	<b>19</b>
<b>11.</b>	<b>Obligatory</b>	<b>19</b>
<b>12.</b>	<b>Daily and periodic maintenance</b>	<b>20</b>
<b>13.</b>	<b>Corrosion Proofing and Storage</b>	<b>20</b>
<b>14.</b>	<b>Loader Operation and Maintenance.</b>	<b>20</b>
<b>15</b>	<b>Troubleshooting.</b>	<b>21</b>
<b>16.</b>	<b>Drawings and scheme.</b>	<b>23</b>



**Fig. 1**

Front Loader KR-34 may be employed with a wide range of changeable implements for agriculture, municipal communication and cleaning works and at construction sites (buckets of various volumes and purposes, hay and silos forks, pallet forks and different grapples etc.).

Mounting and dismounting of Loader to/from the tractor is performed by a single operator within 3-5 minutes, without employment of additional mechanisms.

Loader operation control is effected by help of a single “Joy Stick” handle using additional distributor – (operation variant “B”).

Loader’s design permits to sustain parallel plane movement of the bucket (or other attachments/devices) at a wide range of the boom lifting angle.

To enable quick change of mounted implements, the loader’s boom is equipped with a standard linking “SMS” or “EURO” system mechanism.

For mounted implements which require additional operation functions, (variant “B”) loader may be equipped with an extra electrically governed hydraulic distributor (set/unit of 3-rd function operation).

All hydraulic equipment employed in Loader’s construction (design) conforms to Euro Standards.

## GENERAL CONDITIONS .

### 1. Prior to operation, it is obligatory to study Front Loader Technical Specification and Operation Manual.



Operation and service of the front loader are described in this operating manual. If you have questions concerning the operating manual, contact your dealer. An operating manual is supplied with each machine. It is a component of the front loader and must be kept in the tractor so that the driver or service personnel have immediate access to it for review purposes, if necessary. Obtain a new operating manual immediately if the old manual is damaged or lost.

#### **Attention ! ⚠ Caution ⚠**




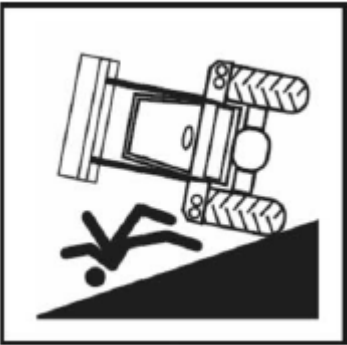
Producer reserves the right to introduce alternations in design, which do not affect general operational characteristics of the loader, without immediate corrections in technical documentation.


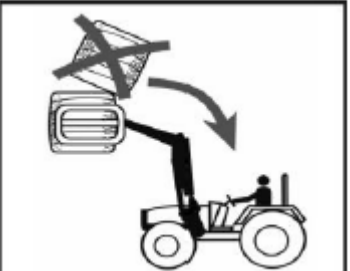

#### **Warning symbols.**

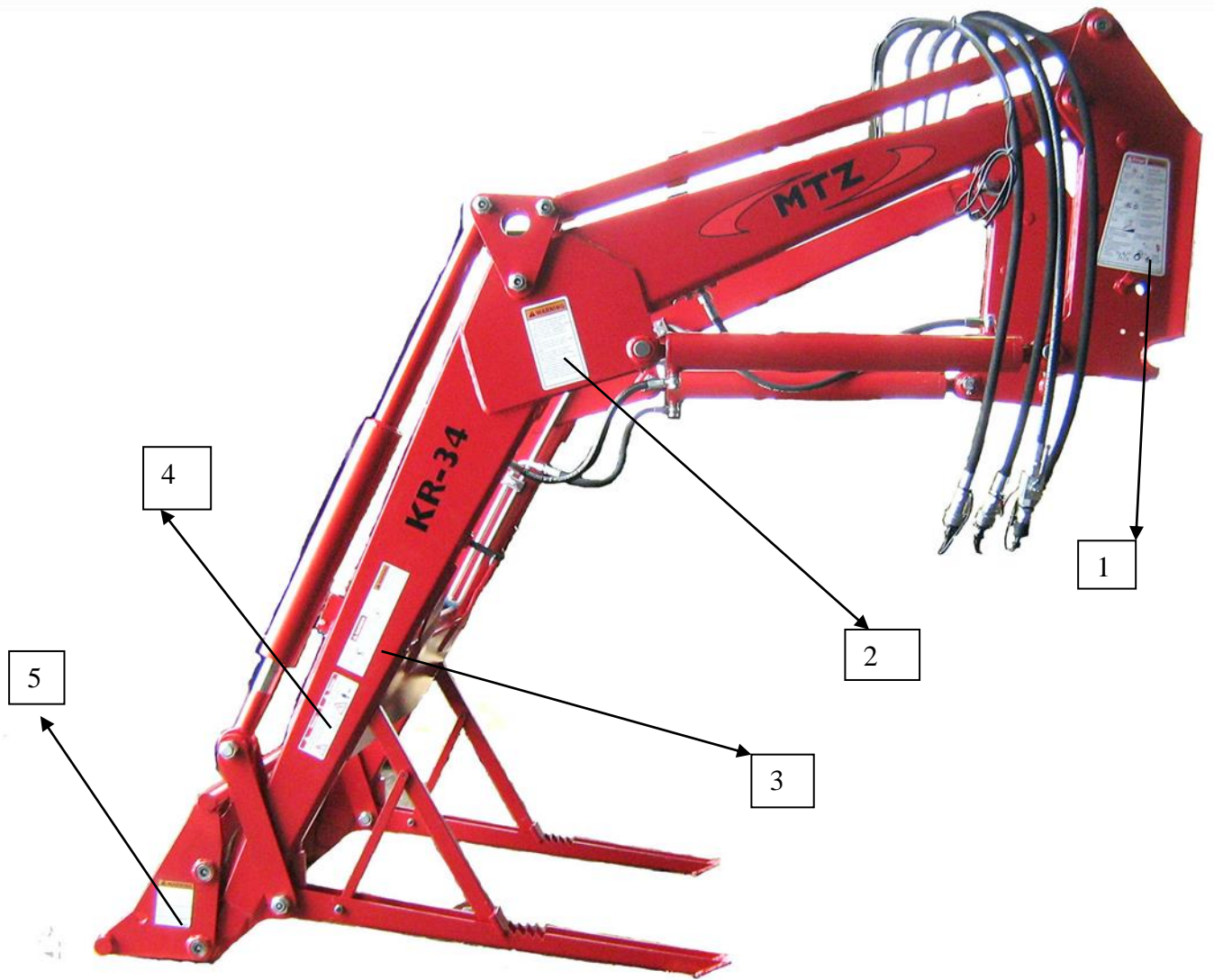
Warnings are used in this manual to protect you from injury and to protect the machine from damage.

Always read and comply with these warnings.

	<p><b>⚠ Danger ⚠ Familiarise yourself with the work area and the terrain. Keep a safe distance away from electrical lines.</b> Only execute front loader work if the visibility conditions are adequate. Ensure that the work area is adequately illuminated. Keep the cab windshield clean.</p>
	<p><b>⚠ Danger ⚠ Do not position yourself in the vicinity of raised front loaders or in the vicinity of an unsecured load.</b></p>

















	<p>Ensure that no one is positioned in the danger zone of the front loader.</p>
	<p><b>▲ Danger ▲</b> Only control the machine from the driver's seat.</p>
	<p><b>▲ Danger ▲</b> Do not lift or carry persons.</p>
	<p><b>▲ Danger ▲</b> Use extreme caution when working on a slope. Do not drive transverse to the slope with a raised load. The danger exists that you and the tractor will tip over. Push the load material together downhill. Scoop up the material in the depression at the bottom of the incline. Extend the wheel track of the tractor. Even with an adjustable axle do not work under the normal track width.</p>

	<p><b>▲ Danger ▲</b> Check the implement tilt when lifting the front loader. Raised loads can fall on you if you scoop the implement too far.</p>
	<p><b>▲ Danger ▲</b> Never stack multiple loads (bales, pallets) on top of each other. The upper loads can fall on you. Special implements, such as baling implements or pallet forks are designed in such a manner that they prevent loads from falling onto the tractor.</p>
	<p><b>▲ Danger ▲</b> Check the implement tilt when lifting the front loader. Raised loads can fall on you if you scoop the implement too far.</p>



Decols front loader KR-34



 <b>Danger</b>	 <b>Caution</b>
  <ul style="list-style-type: none"> <li>• Do not operate with anyone on loader attachment</li> </ul>	<p><b>LOADER SAFETY</b></p> <ul style="list-style-type: none"> <li>• Operate loader only from operator's seat.</li> <li>• When parking or servicing unit, lower attachment to the ground, stop engine, and set the parking brakes.</li> <li>• Lower loader to the ground when parked.</li> </ul>
  <ul style="list-style-type: none"> <li>• Keep loader away from overhead electric lines.</li> </ul>	<p><b>REMOVING OR INSTALLING LOADER</b></p> <ul style="list-style-type: none"> <li>• Park detached loader on hard level grounds.</li> <li>• Have an attachment mounted to loader when removed from tractor.</li> <li>• Do not permit bystanders within 10 feet of loader.</li> <li>• Do not repair loader if not mounted on tractor. Loss of oil or removal of parts could cause loader to collapse.</li> </ul>
  <ul style="list-style-type: none"> <li>• Raised loader or boom can fall from hydraulic system failure.</li> </ul>	<ul style="list-style-type: none"> <li>• Before using loader for the first time, tighten up all threaded unions on hydraulic lines.</li> </ul>
  <ul style="list-style-type: none"> <li>• Use ROPS and seat belt at all times. Add recommended rear ballast. Operate tractor at low speeds.</li> </ul>	  <ul style="list-style-type: none"> <li>• Retighten all screws after 5 hours operation!</li> </ul>
 <ul style="list-style-type: none"> <li>• Do not handle large objects unless loader is equipped with proper attachments.</li> <li>• Operate loader only with approved hydraulic valves. Handle raised loads carefully. Carry load low during transport.</li> </ul> 	
 Failure to comply will result in death or serious injury. 	



2

**! WARNING**

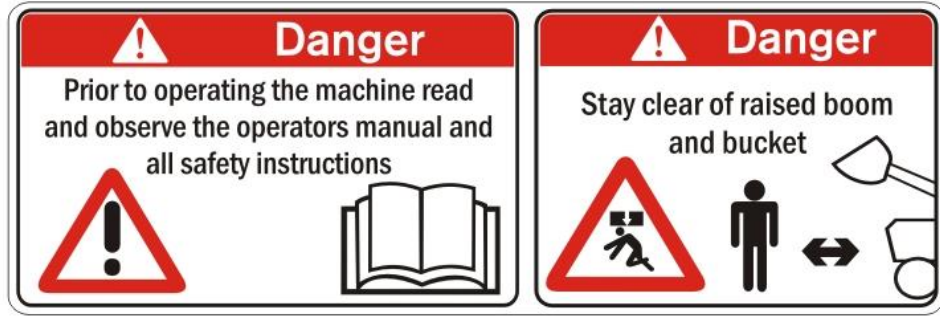
1. Read Operator's Manual before operating.
2. Lower loader arms, stop engine and lock brakes before leaving operator seat.
3. Do not handle round bales or other shiftable objects unless loader is equipped with an attachment designed for this purpose.
4. Do not handle loose loads that are not secured.
5. Move and turn tractor at low speed.
6. Add recommended wheel ballast or weight tractor at end opposite the loader for stability.
7. Carry load no higher than necessary to clear the ground when transporting.
8. Move wheels to widest possible setting to increase stability.
9. Do not lift, carry, or allow anyone to ride on or work from any portion of loader
10. Relieve pressure on system before repairing, adjusting or disconnecting.
11. Stay away from power lines. Electrocutation can occur without direct contact.
12. Review safety instructions annually.

814366

3

	<p><b>! DANGER</b></p> <p><b>ELECTROCUTION HAZARD</b></p> <p>To prevent serious injury or death:</p> <ol style="list-style-type: none"> <li>1. Stay away from power lines. Electrocutation can occur without direct contact.</li> </ol> <p style="text-align: right; font-size: small;">113711</p>		<p><b>! WARNING</b></p> <p><b>OVERHEAD HAZARD</b></p> <p>To prevent serious injury or death:</p> <ol style="list-style-type: none"> <li>1. Do not allow bystanders in loader work area</li> <li>2. Lower loader to the ground before leaving seat.</li> </ol>
---	--	--	---

4



5



**2. Front Loader General Description.**

Front Loader, Model KR-34 is produced as an attachment (mounted equipment) for MTZ 800/900/1000 series tractors. ( towing capacity class 1,2-1,4 tons, with 11,2-20 or 13,6 -20 front tires) and for tractor model MTZ-1220.4

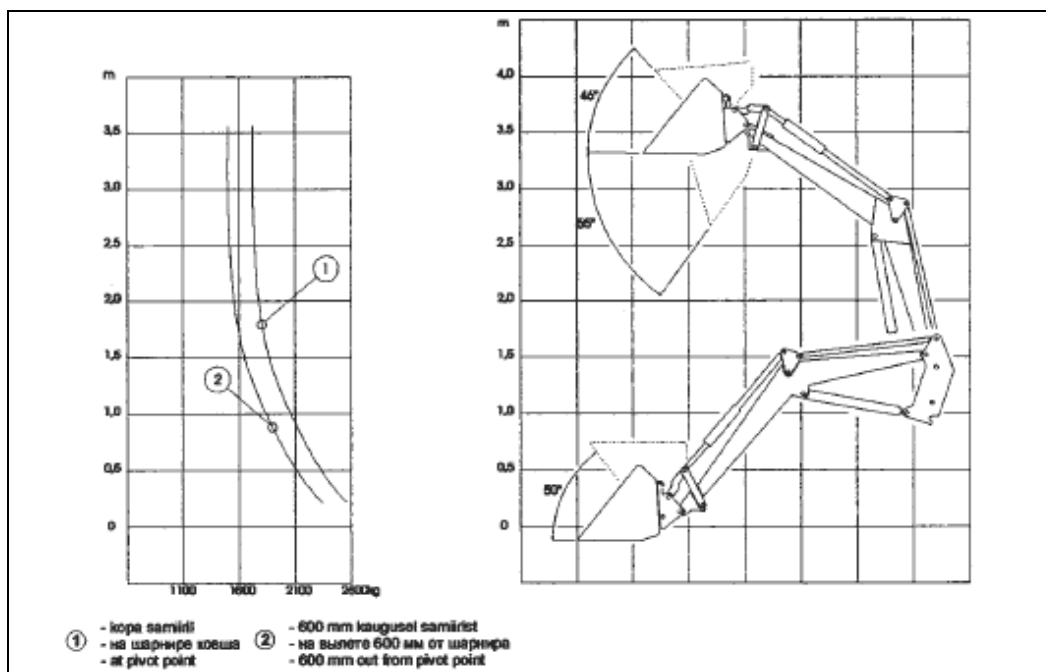
**Attention! ⚠ Danger ⚠** When operations with loads, exceeding 800 kg. counterweight, not less than 800 kg. must be attached to the rear tractor linkage.

### 3. Basic Technical Specification.

1. Hydraulic system pressure (max), bar	160 +5
2. Lifting height as per bucket hinge pivot axle (max), m	3, 45 *
3. Lifting force at maximum height, kg	
- at the bucket pivot point	1600**
- at 600 mm out from pivot point	1200
4. Lifting force at 2 m height, kg	
- at the bucket pivot point	1650
- at 600 mm out from pivot point	1320
5. Unloading angle at the maximum lifting height, degrees	55°
6. Bucket filling angle at ground level position, °	50°
7. Boom lifting time (at 45 dm <sup>3</sup> /min), seconds	5, 2
8. Front loader weight, kg. (without connecting frame)	480

\* - the parameters are appropriate for MTZ 800/900/1000 class tractors with 13,6-20 and 18,4-20 wheel width.

\*\* - the recommendation of the manufacturer of a tractor -do not raise cargoes in weight more than 1200 kg. with a view of safety of the front bridge of a tractor.



Lifting Diagram.

### 4. Assembly Set.

#### 4.1 Complete Loader KR-34 B

Assembly set includes:

pc.

- Loader 3405.16 1
- Set of connection frame and fixings 1
- Connection set and Operation control set "B"(from additional distributor by a single " Joystick" 1
- Technical Specification and Operation Manual 1

### 5. Additionally "by order" :

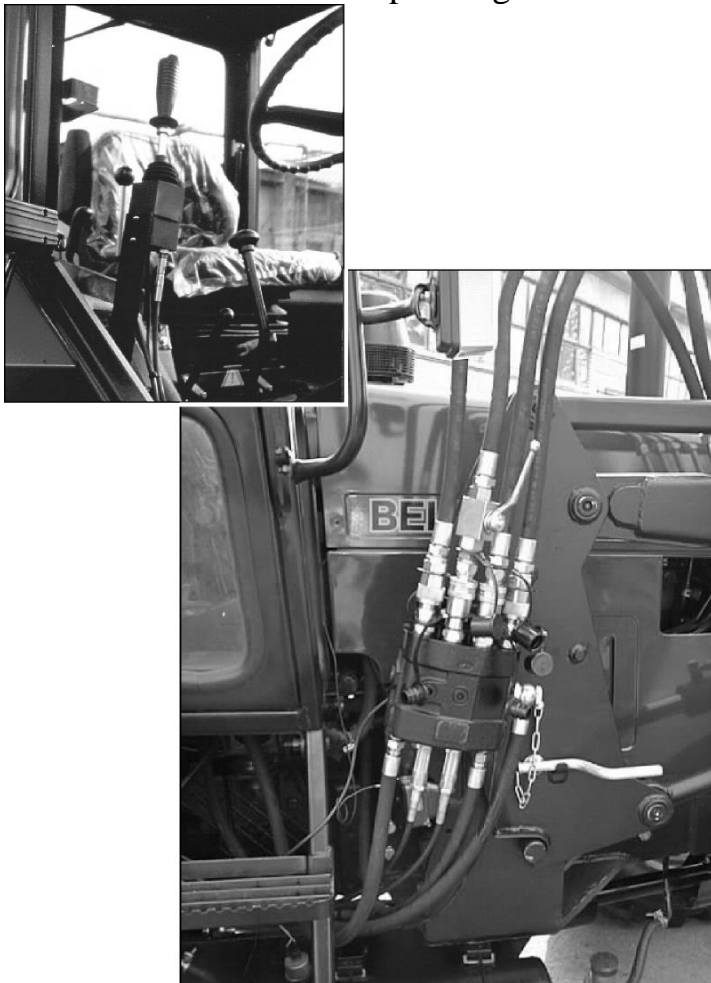
- 5.1. Set for the 3-rd function control.
- 5.2. Shock absorbing valves for "B" control set.

### 6. Control set for additional Distributor by "Joystick" ( Set. "B"- Fig.1A).

Control set "B" comprises an additional distributor, "Joystick" handle, control wire pull-ropes and a set of parts for hydraulic connection – pipes, nuts and intermediate fixtures.

#### 6.1. Distributor.

Additional double section distributor for the front loader is connected directly to hydraulic pump of the tractor, with oil flow outlet attached to tractor hydraulic tank. In case of this additional distributor being idle, oil is directed to tractor distributor as usual, but when front loader is operating – tractor distributor is blocked automatically.



**Fig. 1A** Control set "B" .

When front loader is not operating – tractor distributor is functioning without any limitations. Distributor section which governs bucket turning movements has two unfixed working positions with a forced return into neutral position.

Section which controls boom's lift and lowering, has an additional “flowing” position.

To avoid hydraulic system overload – distributor is equipped with inside security valve. In order to eliminate extra high overload impacts, two additional build-in antishok valves can be ordered to distributor set separately. ( p.13 Fig. 5a)

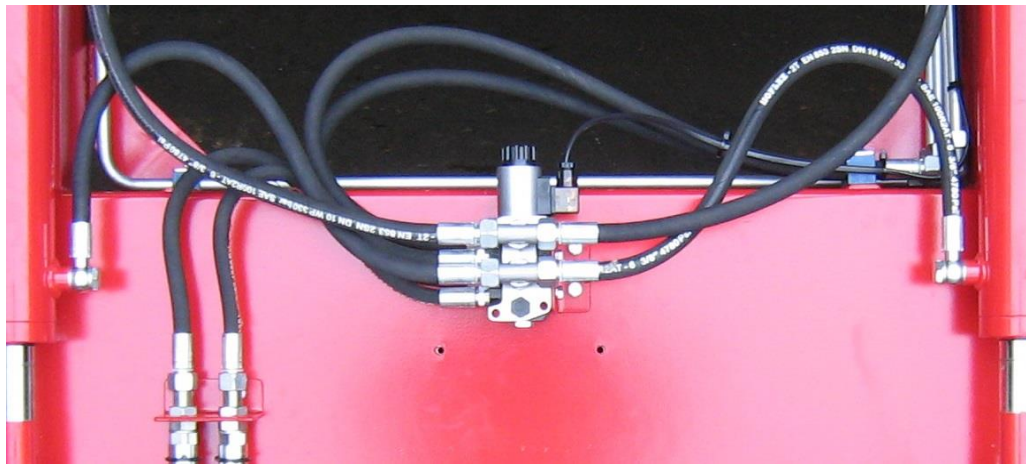
**Attention! ▲ Caution ▲** Loader Hydraulic system is connected to the additional distributor by 4 flexible hydraulic pipes by help of quick acting clutches.

## 6.2 Joystick Handle.

Additional distributor is controlled by a single “Joystick” type handle. Joystick is connected by flexible wire pull-ropes (Bowden cables) with distributor slide-valves. (Fig.5b.)

## 6.3 The 3-rd Function Control Set.

A set of 3-rd function control includes an additional (second) distributor with quick-acting clutches. It is mounted on the cross beam of the loader boom and allow to operate with implements / equipment which requires additional operation movements.



**Fig. 2. 3-rd Section Control set.**

**Attention! ▲ Caution ▲** The 3-rd Function Control set can be employed when frontal loader is equipped with control set “B” variant.

## 7. Preparation of “Belarus” MTZ tractor to operations with KR-34 Loader.

### 7.1 Mounting of connecting frame. (Fig.7)

Forward parts (right and left) of connecting frame (pos. 1 and 2) are attached to the tractor side rails, and back frame beams are fixed on tractor back axle metal hose/collar by help of bolts.

Vertical posts of semi-frames are connected with each other by puller and rear attachment are fixed by puller (7) and attached to the body of tractor’s gear box. The distance between posts is adjusted according ( Fig.1) by means of puller 8.

**Attention ! ▲ Caution ▲** When required, cut-outs to be made in side panels of the engine hood as shown on Fig. 8

### 7.2 Connection to the tractor hydraulic system. ( Control set “B” )

#### 7.2.1 Alternation (rearrangement of tractor hydraulic system):

- **Disconnect** the pipeline of the power position regulator ( Pos.4, Fig. 5) from the flange of the tractor pump (pos.3).
- **Dismount** the pressure pipe, which connects the pump with tractor distributor.
- **Attach connector** (19, Fig.5a) to the distributor (2, Fig.5a).
- **Assemble/adjust the plate** (21, Fig.5a) together with connector (22) and washer (23) on to the pump.

**Attention! Pressure O-ring** from the pressure pipe **must** be used when assembling the plate and the pump.

- **Connect** Power position regulator pressure pipe (4, Fig.5) to the plate (21).
- Hydraulic tank cover cup must be substituted for the pipe connector (20, Fig.5a) – See also Fig. 5C

#### 7.2.2 Mounting and connection of the hydraulic distributor:

- Additional distributor (1, Fig.5a) must be mounted on the frame vertical beam (right or left ) depending on the side of the frontal loader hydraulic system position by help of the bracket ( 3, Fig.5a ).
- **Connect the distributor** according to the assembly scheme ( Fig.5 and 5a) by help of flexible hydraulic sleeves.

**Observe strictly remarks** : “P” – oil feeding **from** the pump,

“T1” – oil feeding **from additional loader distributor to tractor distributor**,

“T” – **oil outlet** flow **from** additional distributor to the tractor oil tank.

#### 7.2.3 Control unit assembly:

- Assemble the “Joystick” handle inside tractor cabin together with flexible wire pull-ropes ( Fig. 5b ).

**Attention! ▲ Caution ▲** In case loader distributor system is mounted on the left side, **pull-ropes** must be placed to the cabin’s left side and positioned under the cabin bottom.

- **Connect** flexible hydraulic sleeves with the distributor ( 1 ) so that



the “Joystick” handle ( 2 ) was in vertical position , and control movements were corresponding to the scheme ( 3 ) attached.

- **Attention!** ▲ **Caution** ▲ In order to connect pull-ropes to distributor slide valves **make use of shafts “A”** and of clutch “B” from distributor assembly set. ( see Fig. 5b )
- **Attention!** ▲ **Caution** ▲ Vertical position of the “Joystick” handle is achieved by adjustment of pull-rope length by help screw nut “C” on the ends of pull-ropes and also by help of connecting clutch “A” ( see Fig. 5b )
- **Warning!** ▲ **Danger** ▲ All movements of the Joystick must be smooth without jerks and without employment of extra force. The wire pull-ropes must not be twisted/ entangled, and avoid their pressure and rubbing to the moving tractor parts.

## 8. CONTROL UNITS.

### 8.1. Frontal Loader Operation Control.

Operation control is effected by a single “Joystick” handle with help of additional distributor. ( See Fig. 3 ).

**Attention!** ▲ **Danger** ▲ **In case there are no operations with loader, the Joystick handle must be blocked in neutral position.**

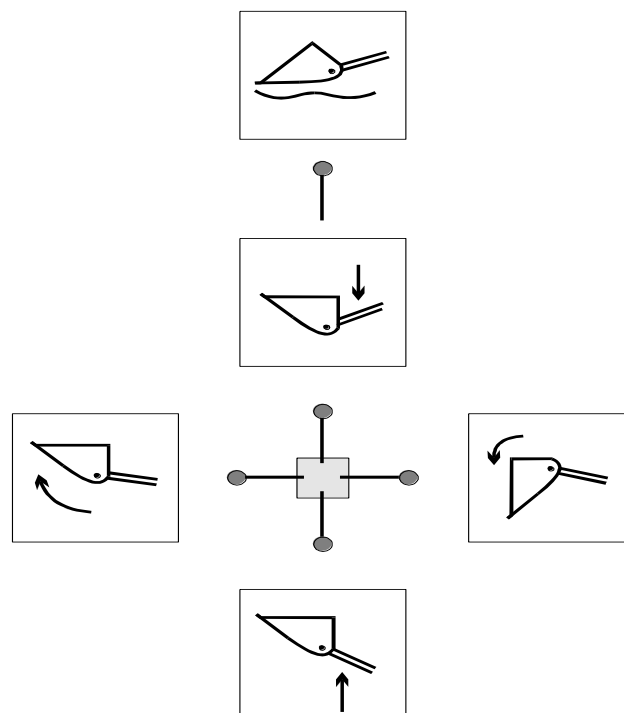
#### Scheme Fig. 3 – details:

Handle movement “Backwards or to the Front is corresponding accordingly to **Up/Lift or Down** movement of the loader boom.

Handle movement to the extreme forward /until stop/ position – corresponds to the definite “**Flow**” mode of the **boom**.

Handle movement “ to the left, then to the right” – corresponds to bucket **filling** and **discharging**.

**Fig. 3 – Frontal loader operation control by Joystick handle.**







**Fig. 4**

## **8.2 Connecting of Front Loader to the tractor.**

- Position the loader on the parking supports in front of the tractor so, that the axles “A” of the loader bracket were at the same height level with the locks of the connecting frame (fig.4).
- By moving the tractor cautiously forward, insert loader’s bracket axles into the connecting frame locking nest. Position fixing rods “F” into the holes of loader bracket and fix them.
- Connect flexible hydraulic system hoses of the loader to the quick - action clutches of the bracket, according to scheme (Fig.1A ).In case, all previously required operations are performed correctly, the boom lifting cylinders will be connected to the left outlets, while bucket turning cylinders - connected to the right tractor outlets.
- Lift the loader’s boom, fold the parking support and fix it to the boom.

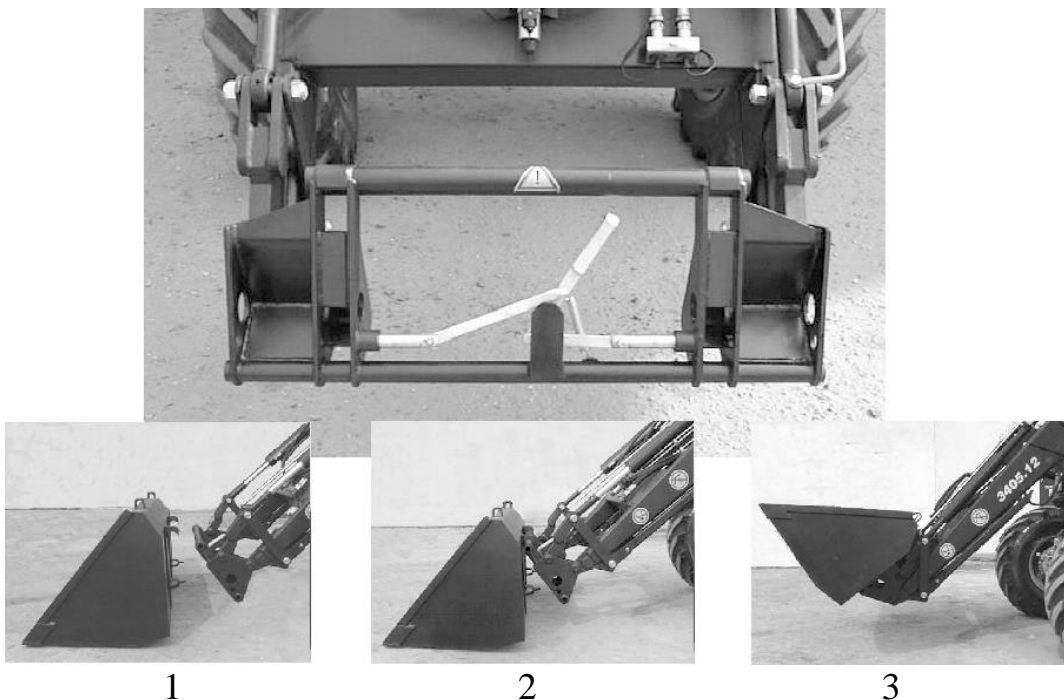
### 8.3 Disconnecting of Front Loader from the tractor.

Disconnection of the front loader is performed in the reverse order.

- Position the bucket to the ground by front edge so, that there was a free space between the ground level and the bottom plate equal to 10 – 15° .
- Unfold parking supports and position them to the ground.
- Place loader brackets so, that the distance between their upper ends and the boom was 50 - 60 mm.
- Remove fixing rods “F”
- Smoothly turning the bucket and lowering the boom, free the loader from connecting frame locks (While this operation, the loader, under its own weight should slip down from connecting frame and rest safely on parking supports).
- Cautiously, without stretching flexible hydraulic hoses, move the tractor backwards to 150 – 200 mm distance.
- By turning the bucket, return bracket axles “A” to the height level of the connecting frame locks.
- Switch off the engine, then by 2-3 movements of the “Joy Stick” handle relieving loader’s hydraulic system from residual pressure, and finally, disconnect the quick-action hose clutches.

### 8.4 Connecting and change of implements.

For quick substitution /change/ of implements loader has a **special Frame** with “SMS” or “EURO” locking mechanism.



To attach a bucket (or another device) to the loader’s boom, it is necessary

to put the “SMS” or “EURO „ locking lever into the “Open” position, mount the bucket by picking bucket hooks by help of the boom upper axle, toss the bucket into “towards body” position and put the lock lever into “Close” position.

### **8.5 Connection and change of hydraulically operated implements as units of the “3-rd Function Set”.**

In order to connect flexible hoses of hydraulically operated implements (grapples, hydraulically governed buckets, etc.) to the quick couplers of the “3-rd Function Control Set” it is necessary:

- To move forward the quick coupler this is fixed on boom (Fig.2).  
When being moved it must spread and open.
- Insert the flexible hose end of the used implement inside the coupler and move the quick coupler back / down.

After this the coupler will catch the hose end and contracts and closes by itself. To disconnect the hoses, it is necessary to move couplers forward, and the hoses shall be released automatically.

**Attention! ▲ Danger ▲** To preserve flexible hoses safe and undamaged, do not forget to remove them before any implement is dismantled from the Loader.

## **9. ▲ Caution ▲ Safety Measures.**

9.1 Prior to starting your work, it is obligatory to check the safety condition of fixing parts, hydraulic system couplings and connectors and absence of damages in metal pipes and flexible hoses.

9.2 While switching tractor’s engine “On” and “Off” the loader boom must be in the lowest/ “down” / position.

9.3 While on move with load, the boom must have lower position.

9.4 “Float position” mode of the boom **must not, in no case, be switched “OFF”** when loaded bucket is in its highest upper position.

9.5 When transporting loads for a long distance, at long-period parking and during repair and maintenance works, the tap (Fig.A1) must be in “Closed” position.

9.6 Before starting work, it is necessary to find out if there are big stones, deep pits or other bulky objects in order to avoid them while operation.

9.7 Before stepping out of cabin, it is obligatory to move the boom down to lowest / ground position.

9.8 The engine has to be switched “Off” before leaving the machine.

9.9 Extra attention at works is needed and strict safety measures to be taken in constraint space circumstances and under restricted visibility conditions. The working site must be properly lighted. Keep the cab windshield clean.

9.10 When working in the vicinity of electric lines and power cables utmost caution must be exercised.

9.11 When performing any work by frontal loader it is obligatory to use **counterweight not less than 800 kgs.**

9.12 Parking of the Loader must be performed at even ground and special attention must be taken, that the hydraulic system is completely relieved from oil pressure. Only park the front loader on a stable substrate and with attached implement. Ensure that the support legs are securely positioned.

9.13 If you use the front loader at low outdoor temperatures, bring the hydraulic system up to working temperature beforehand. To do this, completely extend and retract all hydraulic cylinders several times.

9.14 If the tractor has as a seat belt, fasten the seat belt when driving.

9.15 Only control the machine from the driver's seat.

9.16 When driving on curves reduce the speed and lower the load.

9.17 Only the operator should attach and remove the front loader and the implements.

9.18 The recommendation of the manufacturer of a tractor -do not raise cargoes in weight more than 1200 kg. with a view of safety of the front bridge of a tractor.

## 10 PROHIBITED ! **Danger**

- To disconnect hydraulic system couplings with switched engine and raised boom.
  - To operate the loader when quick-linkage device is open.
  - To lift or transport people on the loader.
  - To be within loader's working range and stay under lifted boom.
  - To try filling the bucket by compressed, bulky, frozen, but not loosened materials or use loader for crushing such materials.
- To exceed the stipulated (specified) maximum working pressure in loader hydraulic system.
- To move with transport speed more than 20 km/h
- To operate with working speed more than 6 km/h
- To operate on ground slopes exceeding 5°
- To transport loads via rough pitted terrain.
- To drive on public roads with loaded implement.

## 11. Obligatory.

- To take care that all loader and tractor warning tables and labels are visible and undamaged.
- To take measures that the load is distributed evenly along bucket (or other devices) width and strive to place loads symmetrically relatively to the longitudinal tractor axle.

## 12. Daily and periodic maintenance is performed together with tractor maintenance and includes the following procedures:

- Control of hydraulic system couplings leakage tightness and check of hoses and fixing elements safety.

- Checking condition of all loader joints and hinges and presence of lubrication inside.
- Checking of safe loader fixation to the connecting frame.
- Oil level checking in tractor hydraulic tank  
(See: tractor instruction).

**▲ Caution ▲** Lubrication of loader joints and hinges is performed through available lubrication pressure cups, using “Mobillux”, “Alvania Grease 2” types of grease.

### 13. Corrosion Proofing and Storage.

When being stored for more than 3 months, loader 3405.16 must undergo anti-corrosion proofing as per the following procedures:

- Loader hydraulic system must be relieved from residual pressure. Connecting couplings – to be covered by safety caps and plugs.
- Loader is disconnected from the tractor and stationed on parking supports.
- Hydraulic cylinder rods and other unpainted metal surfaces should be grease-proofed.
- Storage is performed under roof cover.

### 14. Loader Operation and Maintenance.

Careful and professional way of loader operation and maintenance are basic factors for safe, reliable and long-term service of a front loader.

**Attention! ▲ Caution ▲** While working with loader, Tractor Operation and Maintenance Instructions must be observed.

Before starting maintenance work, put on your protective equipment (protective overalls, gloves, protective goggles, safety footwear).

Loader requires timely cleaning and in particular – joints and hinges, hydraulic cylinder rods, pipelines, hydraulic devices and coupling, fixing mechanisms. Especially, cleaning is important in frost periods.

Take care of hydraulic clutches and couplings cleanliness. When disconnected, they must be tightly covered by safety caps and plugs.

**Attention! ▲ Danger ▲** Never search for leaks with your fingers. Use suitable aids (a piece of wood or cardboard).

Avoid damage hydraulic flexible hoses and metal pipes. When oil leakage is observed – immediate measures to be taken to eliminate it.

Loader undergoes considerable working loads, and therefore, regular checking of bolt-and-nut tight fixing must be observed.

**Attention ! ▲ Caution ▲ All loader clutches and couplings are of restored type. When mechanical wear is found (free play, gaps), change replacement bushings for new ones and, in some cases, substitute axles as well.**

## 15. Troubleshooting.

Faults on the front loader are frequently caused by factors that are not due to a front loader malfunction. Many problems can be avoided through regular maintenance.

If there are faults, please check the following first:

- Is there sufficient oil in the tractor's hydraulic oil tank?
- Are you using the right oil? Only use oil as specified by the operating manual of the tractor. The wrong oil can cause foaming and leaks.
- Is the hydraulic oil clean and free of moisture? Replace oil and filter if necessary.
- Are hoses correctly mounted? The connections must be locked in place.
- Are hoses and connections damaged, jammed, or twisted?
- Were the cylinders of the front loader moved into their end positions several times to get the air out of lines and cylinders?
- Have you taken low outside temperature into account? Has the oil reached operating temperature? If the measures described above are unsuccessful, the following table may help you to localise and correct the fault. If you require support, contact your dealer.

Fault description	Cause	Fault correction
1. Low lifting and tearing forces.	Insufficient oil pressure.	Check the tractor hydraulics.
2. Operating lever difficult to move.	Bowden flexible cables are difficult to move.	Check the routing and ease of movement of the Bowden cables. Oil or replace the Bowden cables.
3. Front loader and implement move too slowly or do not move at all.	1) Insufficient oil in the hydraulic system. 2) Hydraulic couplings incorrectly connected. 3) Hydraulic coupling defective. 4) Oil flow too low. 5) Pressure control valve of the loader jams in open position.	Check oil level and top off if necessary. Check connections. Check couplings, replace if necessary. Check the tractor hydraulics. Check the pressure in the hydraulic system.
4. Front loader and/or implement work in the wrong direction relative to the operating lever.	1) Hydraulic connection incorrectly connected. 2) Bowden cables incorrectly	Check the hydraulic connections, correct if necessary. Check the Bowden cable

	mounted.	connection, correct if necessary
5. Slow or uneven lifting of the front loader.	<ol style="list-style-type: none"> <li>1) Insufficient oil in the hydraulic system.</li> <li>2) Insufficient engine rpm.</li> <li>3) Hydraulic fluid too cold.</li> <li>4) Excessive load in the vehicle.</li> <li>5) Hydraulic coupling defective.</li> <li>6) Internal leakage in the hydraulic cylinder.</li> <li>7) Pressure control valve set incorrectly.</li> <li>8) Interior leakage in the control block.</li> </ol>	<p>Check oil level and top off if necessary.  Increase engine rpm.  Warm hydraulic system to working temperature.  Decrease load.  Check couplings, replace if necessary.  Check the cylinders, repair or replace defective cylinders.  Check the setting of the pressure control valve.  Check control block, replace if necessary.</p>
6. Insufficient lifting force.	<ol style="list-style-type: none"> <li>1) Internal leakage in the hydraulic cylinder.</li> <li>2) Excessive load in the vehicle.</li> <li>3) Pressure control valve set incorrectly.</li> <li>4) Interior leakage in the control block.</li> </ol>	<p>Check the cylinders, repair or replace defective cylinders.  Decrease load.  Check the setting of the pressure control valve.  Check control block, replace if necessary.</p>
7. Air in the hydraulic system.	<ol style="list-style-type: none"> <li>1) Hydraulic pump takes in air.</li> <li>2) Hydraulic filter fouled.</li> </ol>	<p>Check the lines between hydraulic pump and tank for loose or defective connections.  Check or replace hydraulic filter as necessary.</p>
8. Leakage on the hydraulic couplings of the front loader or the 3rd control circuit.	Leak due to penetrating grime.	<p>Clean coupling, replace if necessary.  If the front loader or the 3rd control circuits are not used, seal the hydraulic couplings with the protective caps.</p>
9. Front loader blocked during the lift or lowering movement.	<ol style="list-style-type: none"> <li>1) Coupling not completely closed.</li> <li>2) Coupling defective.</li> </ol>	<p>Check the hydraulic coupling.  Replace defective coupling halves.</p>
10. Front loader shakes when lowering loads.	Lowering speed too high.	Throttle lowering speed.



## 16. Appendix.

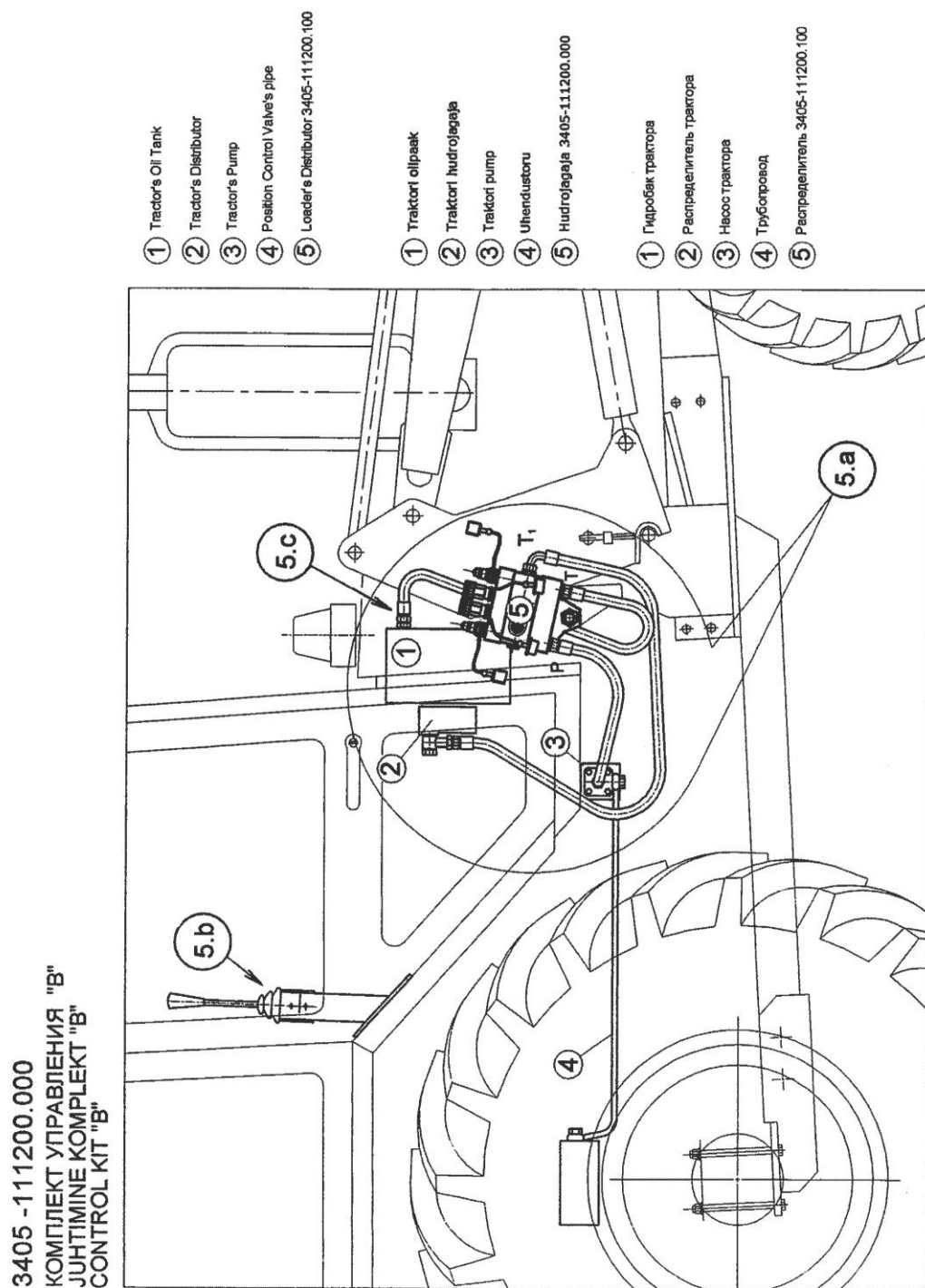


Рис.5 Подключение к трактору "Вариант В"  
Joon.5 Lülitamise traktorile "Variant B"  
Fig.5 Connecting to tractor "Kit B"

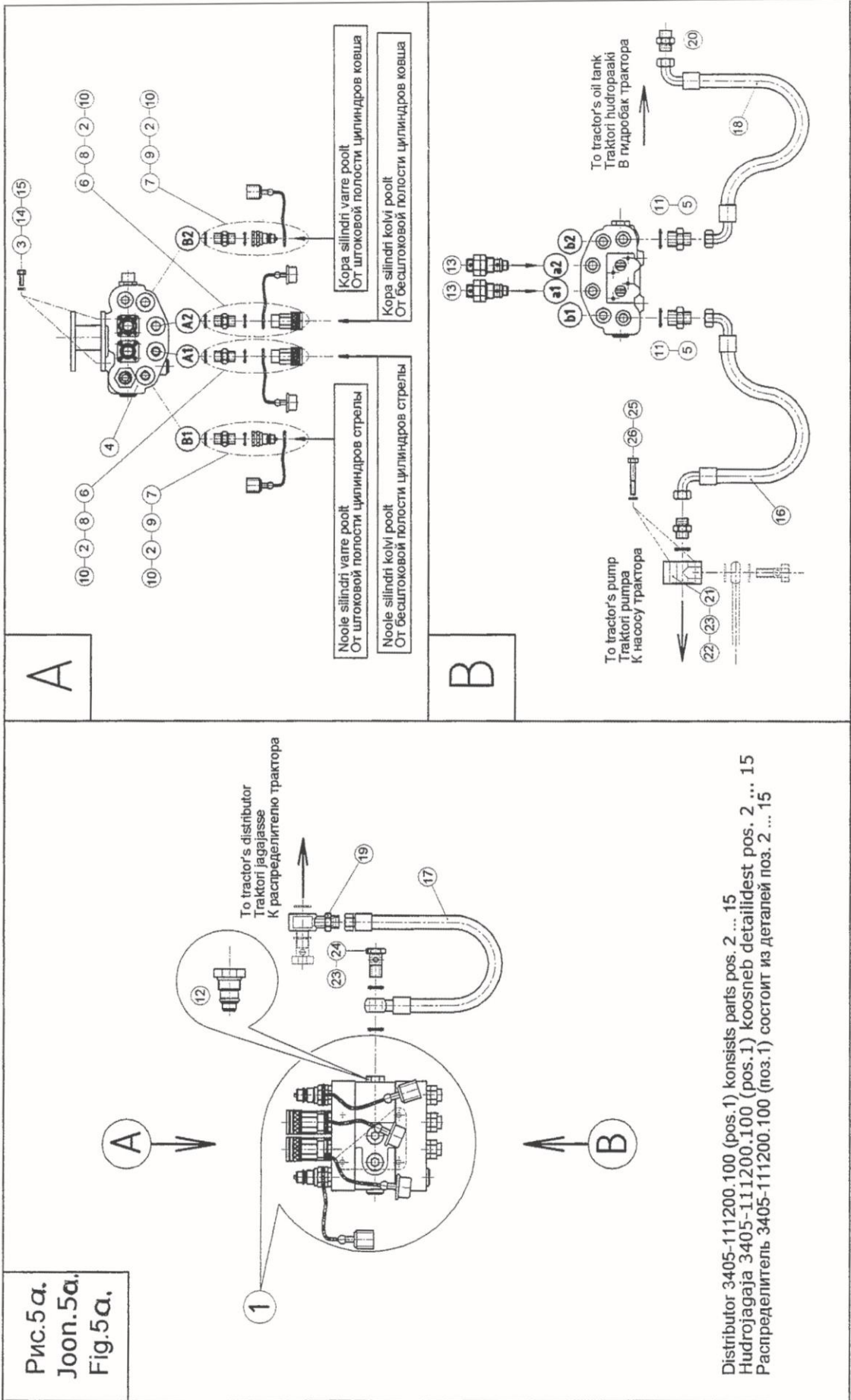
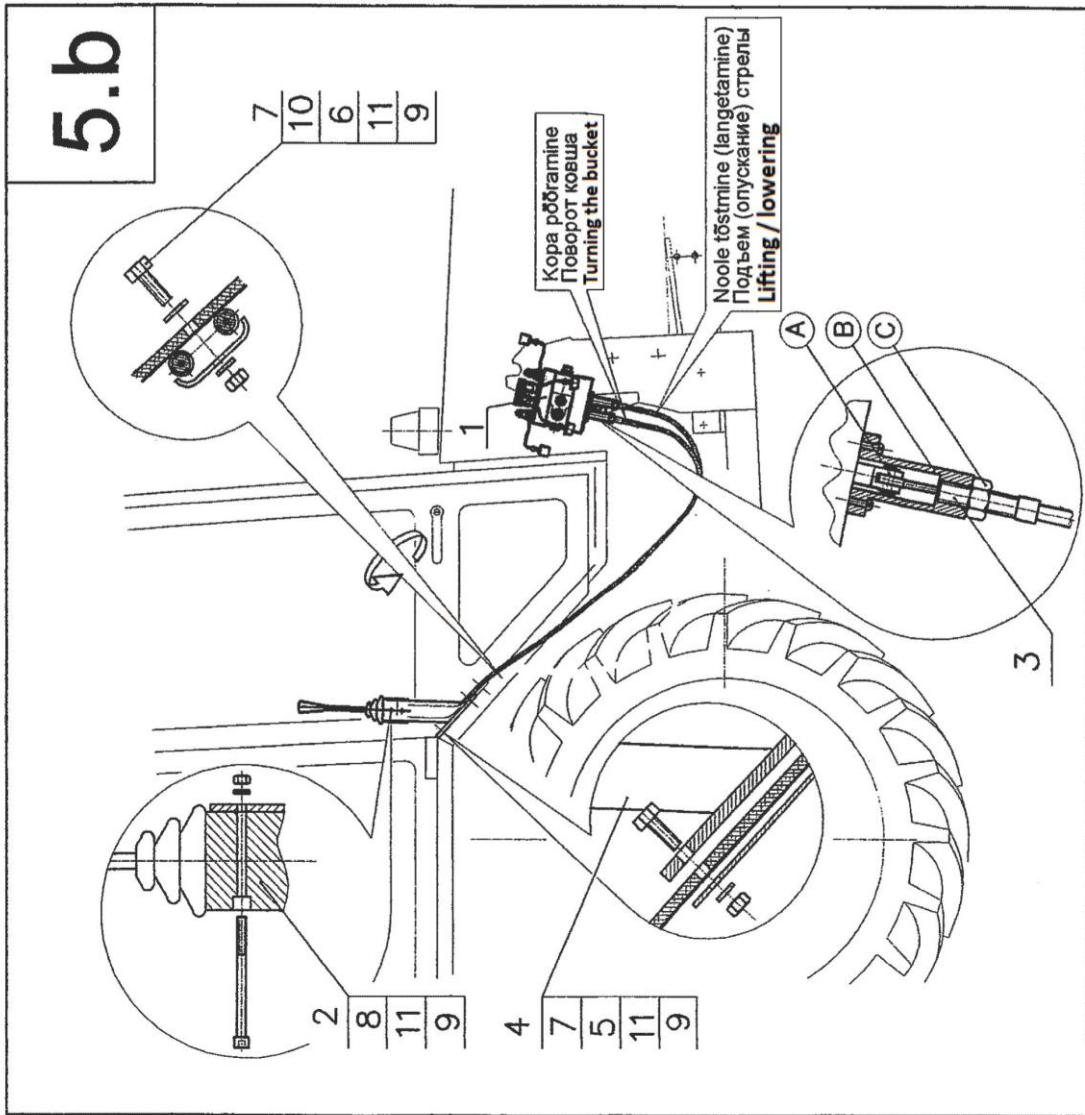


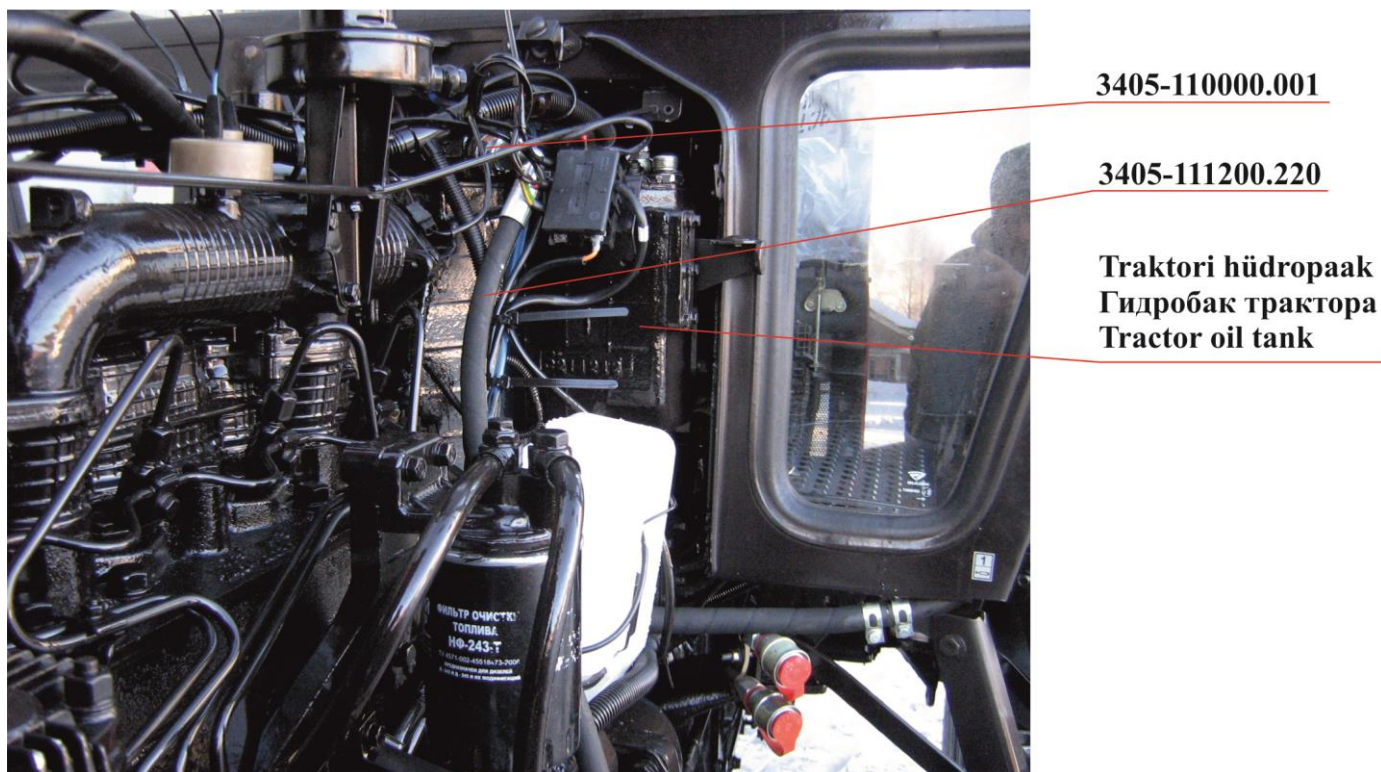
Fig.5a Distributor 3405-111200.000 complete set.

No	Part number	Description	Qty	Note
26	DIN 127	Spring washer	4	
25	DIN 601	Bolt M8x60	4	
24	3080-00-08	Bolt "BANJO" 1/2"	3	
23	USIT 08	Packing ring 1/2"	2	
22	3005-08	Nippel 1/2"/1/2"	1	7002-08-08
21	3405-110000.002	Plate	1	
20	3405-110000.001	Nippel M22/M24	1	
19	3405-110000.100	Adaptor D24	1	
18	3405-111200.220	Hose 1/2"	1	L=1250 mm
17	3405-111200.210	Hose 1/2"	1	L=1000 mm
16	3405-111200.200	Hose 1/2"	1	L=1050 mm
15	DIN127	Spring washer	3	
14	DIN601	Bolt M8x20	3	
13	SD8U(G2)	Valve P=180bar	2	By order
12	XGIU 532474 (MAE)	Coupling MAE12	1	
11	USIT12	Packing ring 3/4"	2	
10	USIT08	Packing ring 1/2"	8	
9	C26915-08	Safety cap	2	
8	C26914-08	Dust cover	2	
7	C23072-08	Plug of coupling	2	
6	C23071-08	Coupler	2	
5	30005-08-12	Nippel 3/4"/1/2 "	2	400-08-12
4	SDM122/2	Distributor	1	
3	3405-111200.110	Bracket	1	
2	3405-110000.004	Nippel 1/2"/1/2"	4	
1	3405-111200.100	Distributor		Consist pos.2...15



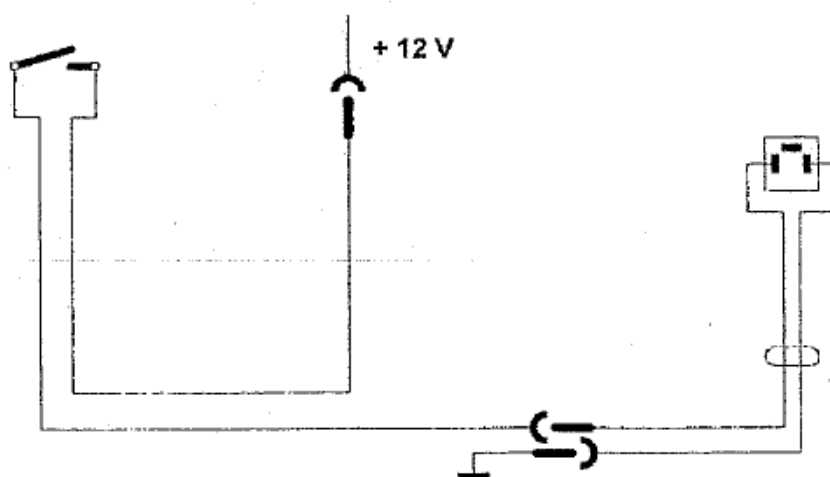
1	3405-111200.100	Distributor	1
2		Joystick handle	1
3	L=2500mm	Flexible cable	1
4	3405-110300.000	Bracket	1
5	3405-110000.016	Strip	1
6	3405-110000.017	Strip	1
7	DIN 961	Bolt M8x35	3
8	DIN 912	Screw M8x80	4
9	DIN 126	Washer M8	4
10	DIN 127	Nut M8	4
11	DIN 127	Spring washer M8	4
	Part number	Description	Pc

Fig. 5b. Mounting scheme on tractor controls variant „B“ with distributor SDM 122/2



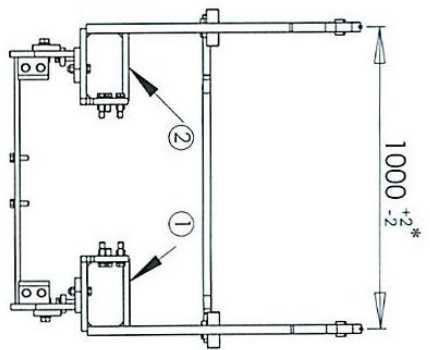
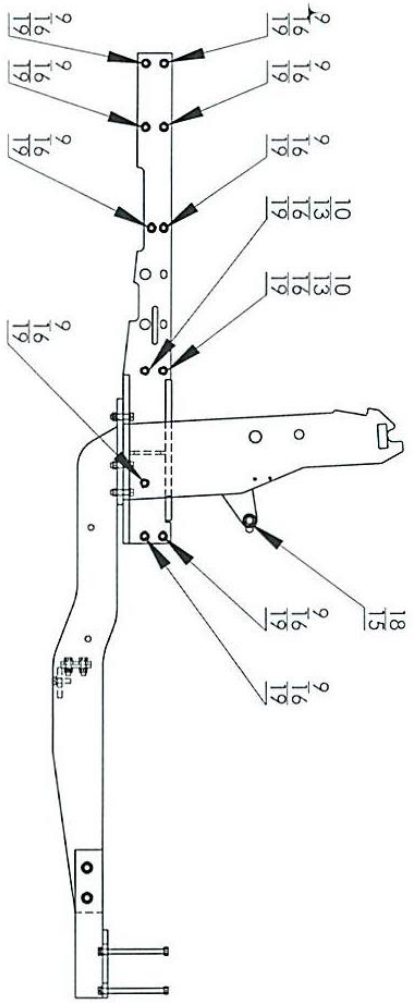
**Fig.5c. Connection of distributor to tractors oil tank.**

Part number	Name	Quantity
3405-110000.001	Nippel	1
3405-111200.220	Hose	1

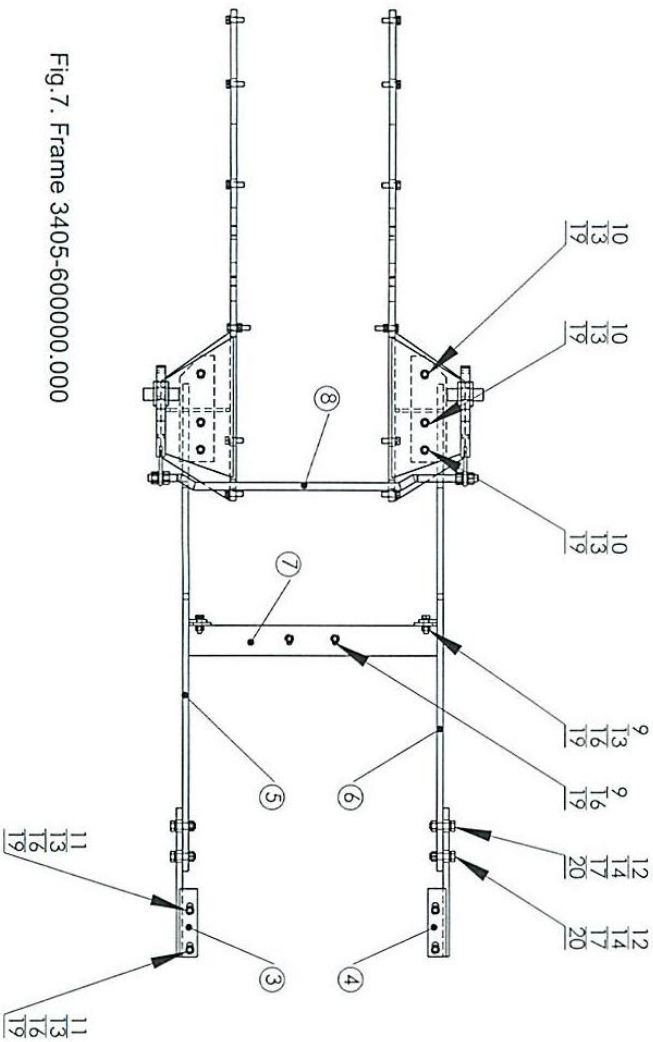


**Fig.6.**  
**Connection cheme of 3 F Kit valve**  
**to tractors electrical system.**



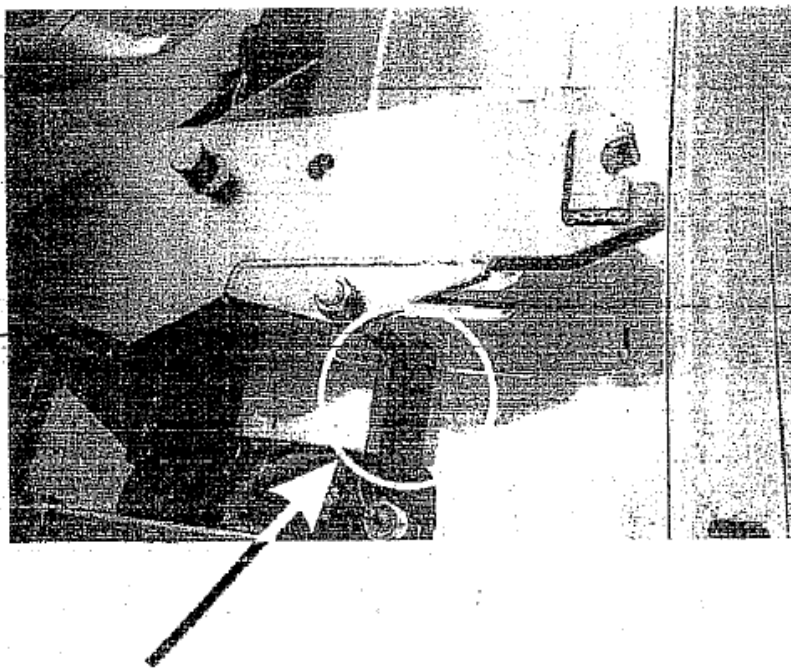
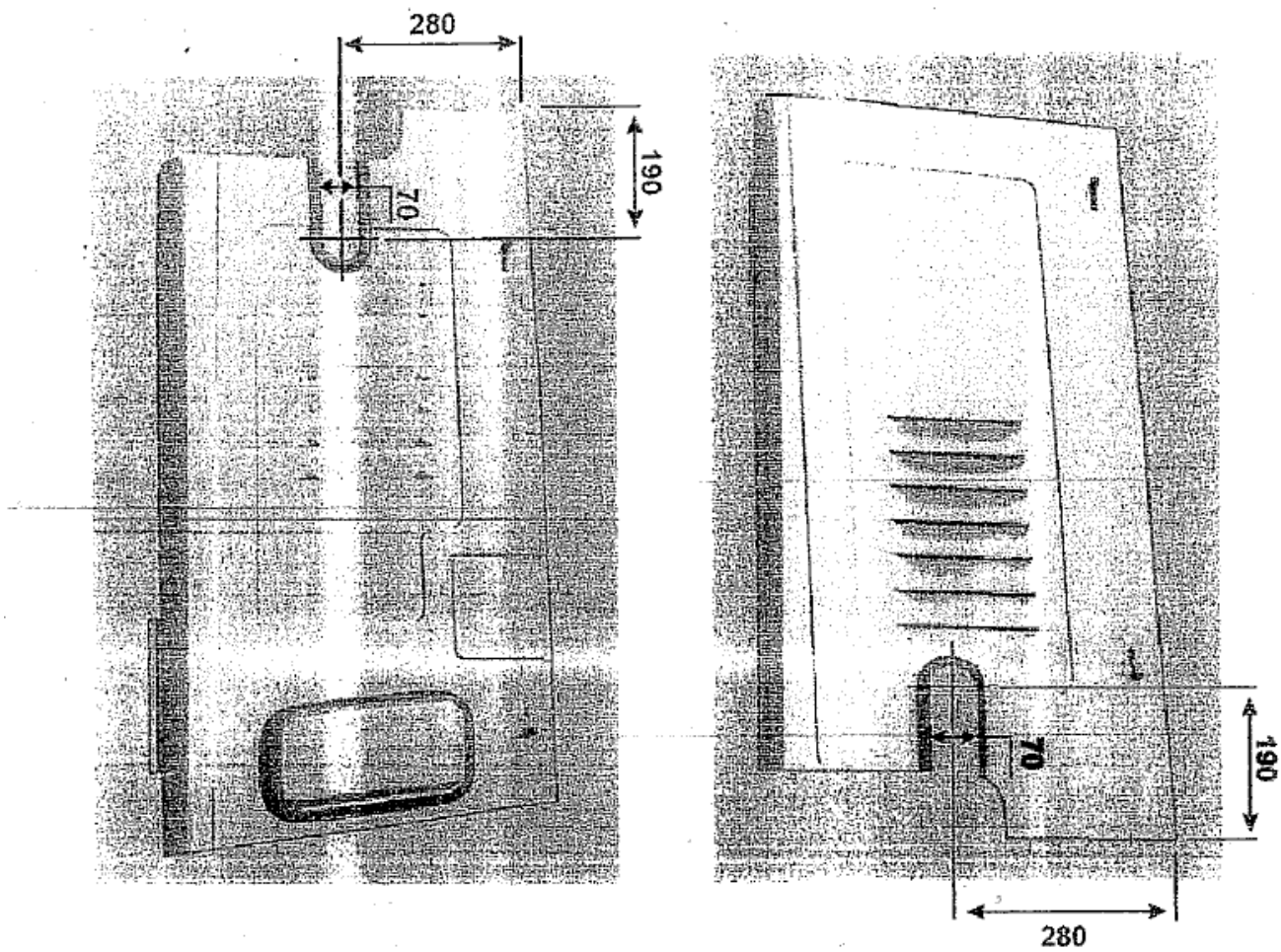


\* measure ensure on assembling



20	20 DIN 127	Lock washer	4
19	16 DIN 127	Lock washer	44
18	24 DIN 125	Washer	4
17	20 DIN 125	Washer	4
16	16 DIN 125	Washer	44
15	M24,6,6 DIN 934	Nut	4
14	M20,6,6 DIN 934	Nut	4
13	M16,6,6 DIN 934	Nut	20
12	M20 x 70,8,8 DIN 931	Bolt	4
11	M16 x 220,8,8 DIN 931	Bolt	4
10	M16 x 65,8,8 DIN 931	Bolt	10
9	M16 x 50,8,8 DIN 933	Bolt	32
8	3405-6000000.001	Puller	1
7	3405-600400.000	Puller	1
6	3405-600300.000-010	Rear attachment	1
5	3405-600300.000	Rear attachment	1
4	3405-600200.000-010	Bracket	1
3	3405-600200.000	Bracket	1
2	3405-600100.000-010	Frame	1
1	3405-600100.000	Frame	1

Fig.7. Frame 3405-6000000.000



**Cut-outs in side panels of the engine hood.**

**Fig.8.**